

S

optical sensing

Optical Fiber Sensors Guide

Fundamentals & Applications



Table of Contents

- Section I:** Optical Fiber Fundamentals
- Introduction
 - Optical fiber structure and characteristics
- Section II:** Introduction to Optical Fiber Sensors
- Operating principle
 - Benefits & advantages
 - Fiber optic sensor classification
- Section III:** Fiber Bragg Gratings
- Introduction
 - Operating principle
 - Fabrication Techniques
 - Interrogation methods
 - WDM
 - TDM
 - Long term Stability and Reliability
 - Strain Sensing
 - Temperature & Pressure Sensing
 - Magnetic & Electric Field Sensing
 - Chemical Sensing
- Section IV:** Optical Fiber Fabry-Perot Sensors
- Principle of the Extrinsic EFPI Fiber Sensor
- Section V:** References
- Section VI:** Suggested Bibliography

I. Optical Fiber Fundamentals

Introduction

The field of fiber optics has undergone tremendous growth and advancement over the last 25 years. Initially conceived as a medium to carry light and images for medical endoscopic applications, optical fibers were later proposed in the mid 1960's as an adequate information-carrying medium for telecommunication applications. Ever since, optical fiber technology has been the subject of considerable research and development to the point that today light wave communication systems have become the preferred method to transmit vast amounts of data and information from one point to another. Among the reasons why optical fibers are such an attractive are their low loss, high bandwidth, immunity to electromagnetic interference (EMI), small size, light weight, safety, relatively low cost, low maintenance, etc.

Optical fiber structure & characteristics

At the heart of this technology is the optical fiber itself -- a hair-thin cylindrical filament made of glass that is able to guide light through itself by confining it within regions having different optical indices of refraction. A typical fiber structure is depicted in Fig. 1. The central portion—where most of the light travels—is called the core. Surrounding the core there is a region having a lower index of refraction, called the cladding. Light is trapped inside the core and travels along the fiber by bouncing off the interfaces with the cladding. This effect is called total internal reflection.

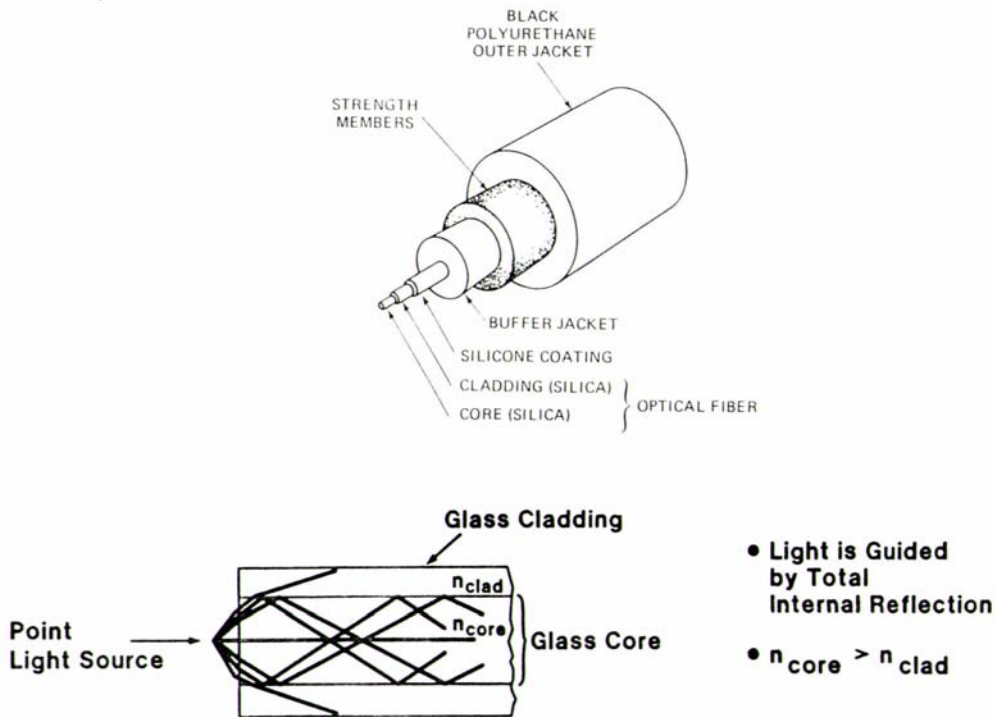

Figure 2.1: Schematic of an optical fiber.

II. Introduction to Optical Fiber Sensors

Operating Principle

Optical fibers are also attractive for applications in sensing, control and instrumentation. In these areas, optical fibers have made a significant. For these applications fibers are made more susceptible and sensitive to the same external mechanisms against which fibers were made to be immune for their effective operation in telecommunications.

An optical fiber sensing system is basically composed of a light source, optical fiber; a sensing element or transducer and a detector (see Fig. 2.2). The principle of operation of a fiber sensor is that the transducer modulates some parameter of the optical system (intensity, wavelength, polarization, phase, etc.) which gives rise to a change in the characteristics of the optical signal received at the detector.

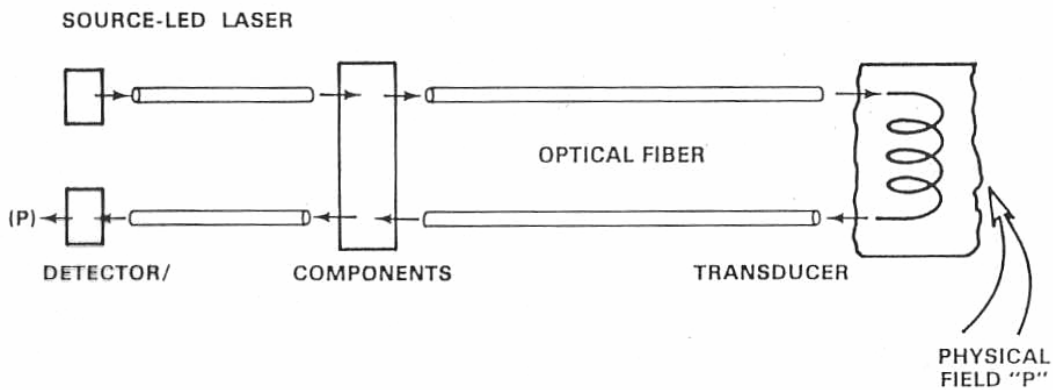

Figure 2.2: Basic elements of an optical fiber sensing system

The fiber sensor can be either an intrinsic one--if the modulation takes place directly in the fiber--or extrinsic, if the modulation is performed by some external transducer as depicted in Fig. 2.3.

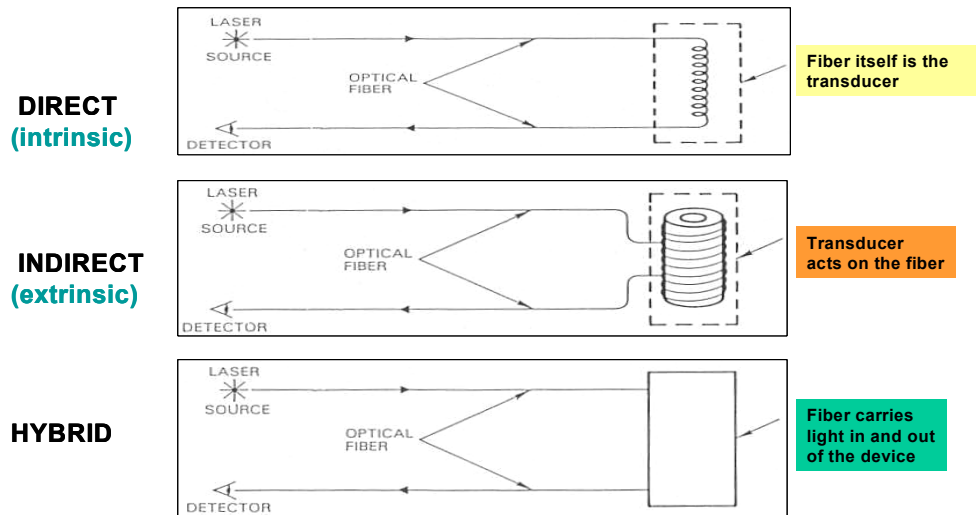
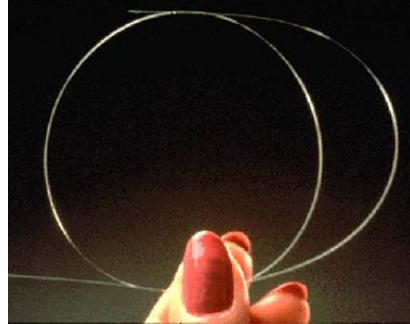

Figure 2.3: Classification of optical fiber sensors

Benefits & Advantages

Optical fiber sensors offer attractive characteristics that make them very suitable and, in some cases, the only viable sensing solution. Some of the key attributes of fiber sensors are summarized below.

- absolute measurement
- immunity to electromagnetic interference
- excellent resolution and range
- passive operation, intrinsically safe
- water and corrosion resistant
- rugged, small size and light weight
- multiplexed in parallel or in series
- modest cost per channel



III. Fiber Bragg Gratings

Introduction

Fiber Bragg gratings (FBGs) have, over the last few years, been used extensively in the telecommunication industry for dense wavelength division demultiplexing, dispersion compensation, laser stabilization, and erbium amplifier gain flattening. In addition, FBGs have been used for a wide variety of sensing applications including monitoring of civil structures (highways, bridges, buildings, dams, etc.), smart manufacturing and non-destructive testing (composites, laminates, etc.), remote sensing (oil wells, power cables, pipelines, space stations, etc.), smart structures (airplane wings, ship hulls, buildings, sports equipment, etc.), as well as traditional strain, pressure and temperature sensing. The main advantage of FBGs for sensing is that these devices perform a direct transformation of the sensed parameter to optical wavelength, independent of light levels, connector or fiber losses, or other FBGs at different wavelengths. Advantages of FBGs over resistive foil strain gauges include:

- 1) totally passive (no resistive heating),
- 2) small size (can be embedded or laminated),
- 3) narrowband with wide wavelength operating range (can be highly multiplexed),
- 4) non-conductive (immune to electromagnetic interference),
- 5) environmentally more stable (glass compared to copper), and
- 6) low fiber loss at 1550 nm (for remote sensing). In addition, FBG's have the potential for a very low cost due to device simplicity and high volume telecommunication usage.

Operating principle

A fiber Bragg grating is wavelength-dependent filter/reflector formed by introducing a periodic refractive index structure within the core of an optical fiber. Whenever a broad-spectrum light beam impinges on the grating, will have a portion of its energy transmitted through, and another reflected off as depicted in Fig. 3.1 The reflected light signal will be very narrow and will be centered at the Bragg wavelength which corresponds to twice the periodic unit spacing Λ . Any change in the modal index or grating pitch of the fiber caused by strain or temperature will result in a Bragg wavelength shift.

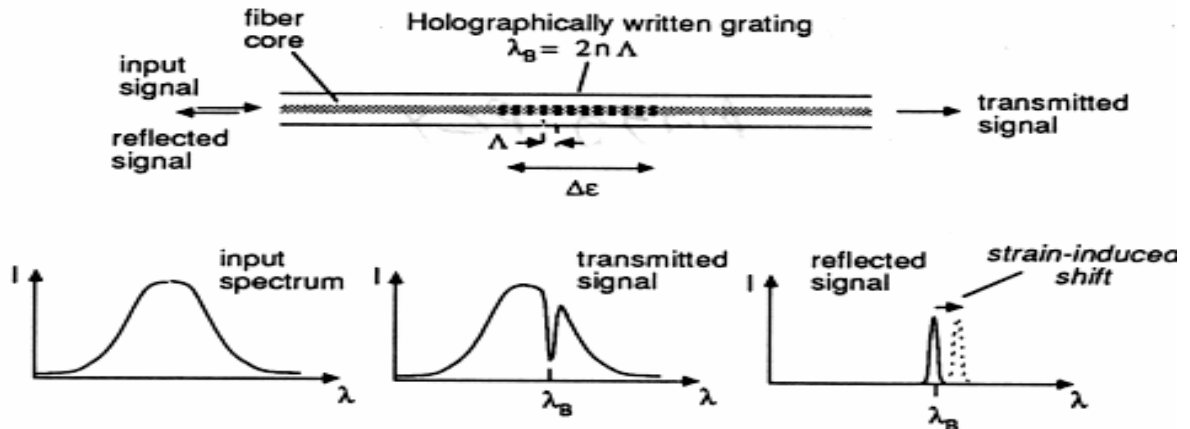

Figure 3.1. Transmission and reflection spectra of a fiber Bragg grating

Strain can be measured using FBG sensors by properly mounting them on or embedding into the substrate of interest. One of the advantages of this technique is the fact that the detected signal is spectrally encoded, so that transmission losses in the fiber are of no concern.

A fiber Bragg grating with a refractive index profile:

$$n(\mathbf{r}) = n_0 + n_1 \cos(\mathbf{K} \cdot \mathbf{r}),$$

where n_0 is the average index, n_1 is the amplitude of the grating (typically 10^{-5} to 10^{-2}) and \mathbf{r} is the distance along the fiber, allows light with wave vector \mathbf{k}_i to be scattered in a direction given by the diffracted wave vector $\mathbf{k}_d = \mathbf{k}_i - \mathbf{K}$. Here $\mathbf{K} = 2\pi/\Lambda$ is the grating vector, its direction is normal to the grating planes. Λ is the grating period. If the diffracted wave vector matches that of the free wave at the incident frequency, strong Bragg diffraction into the \mathbf{k}_d direction occurs. The value of Λ needed to reflect light guided in a single-mode fiber core is given by the first order Bragg condition:

$$\Lambda = \lambda_b / 2n_m$$

where λ_b is the Bragg wavelength and n_m is the effective refractive index of the core mode. The reflectivity is given by

$$\eta = \tanh^2(\rho n_1 L / \lambda_b)$$

where L is the grating length. The grating strength (or amplitude), n_1 , is a function of how long the fiber has been exposed to the UV illumination. The bandwidth of Bragg reflection depends on two parameters: the number N of grating periods, and the strength of the index modulation n_1 . A fraction of the incident light is reflected at each grating plane; if the Bragg condition is not satisfied, then the wavelets reflected at each subsequent plane become progressively more and more out of phase; if, however, the grating strength is sufficient, a substantial proportion of the incident power can be reflected before de-phasing sets in. The balance between the de-phasing length, the physical length of the grating, and the length needed for substantial reflection determines the bandwidth of the Bragg reflection. A general expression for the approximate full-width-half-maximum (FWHM) bandwidth of a grating is:

$$\Delta\lambda/\lambda_b = s \left((n_1/2n_0)^2 + (1/N)^2 \right)^{1/2}$$

The parameter s equals ~ 1 for strong gratings (with near 100% reflection) and ~ 0.5 for weak gratings.

As mentioned before, FBGs are attractive for sensing applications due to the dependence of their spectral shift as a function of grating separation change with external effects. In general, the temperature sensitivity of a grating occurs principally as a result of the temperature dependence of the refractive index in the fiber material and, to a lesser extent, to the thermal expansion in the material which changes the grating period spacing. Typically, the fractional wavelength change in the peak Bragg wavelength is of the order of 10pm/C.

Strain shifts the Bragg wavelength by physically increasing or decreasing the grating spacing by mechanical strain and by changes in the refractive index due to the strain optic effect. For axial loads, the wavelength change is typically 1.2pm per microstrain, or 12nm for 1% strain.

Fabrication techniques

K.O. Hill et al. [1] first observed the formation of a photo-induced grating in a germania-doped optical fiber. Hill's gratings were made in the fiber core by standing wave of 488nm argon laser light. The grating exposure in this case was shown to be a two-photon process. The field did not progress until 1989, when Gerry Meltz et al. [2] of United Technologies proposed that fiber gratings could be formed by exposure through the cladding glass by two interfering beams of coherent UV light, thus exciting the 240 nm band directly by one photon absorption. With transverse exposure technologies, gratings with a wide range of bandwidths and reflectivities can be formed in times between 20 ns (the duration of a 248 nm excimer laser pulse) to a few minutes.

Reliable fabrication of Bragg gratings depends on a detailed knowledge of the underlying mechanisms of photo-induced index changes. The basis of all proposed mechanisms is the ionization of a GeO₂ deficiency centers that exhibit an absorption band centered at 240 nm. Hand et al. [3] suggested that the photo-induced index changes in optical fibers originate from the bleaching of the 240-nm band and the creation of two bands at 281 and 213 nm (this is referred to as the color-center model). Their work explained a photo-induced index change of almost 10^{-4} at visible wavelengths. However, experimental measurements show much larger index changes. To explain the observed large index changes, Sceats et al. [4] proposed thermoelastic stress relaxation of the glass network caused by formation of regions of low density around broken Ge-Si bonds (stress relief model). Alternatively, Bernardin et al.[5] suggested that the UV irradiation may induce rearrangement of the molecular structure, leading to a compaction of the glass matrix (referred to as the compaction model).

Different schemes have been reported for externally writing gratings in optical fibers. They include the conventional two beam-interference scheme [2], diffractive optical element phase mask techniques and the point-by-point method. The most efficient processing technique employs the beam from an argon fluoride (193 nm) or krypton fluoride (248 nm) excimer laser.

The first two methods permit wavelength selectivity by adjustment of the two interfering beams at arbitrary angles. The two beam method requires however many optical components and a stable experimental set-up.

Split beam interferometer

A typical interferometer set-up for fabrication of gratings is shown in Fig. 3.2 UV laser radiation is split into two beams, with an odd number of reflections to preserve beam parity. The two beams are then focused and recombined to form a high contrast fringe pattern within the core of the single mode fiber. The grating formation can be observed by monitoring the reflection or transmission of a broadband source, which is launched into the fiber from one end. After a short

time a notch occurs in the transmitted spectrum, as schematically shown on the optical spectrum analyzer trace in Fig. 4.2 the exposure is stopped when the desired reflectivity is reached and then the grating is annealed to avoid any variations in wavelength due to thermal deactivation of low-energy color centers.

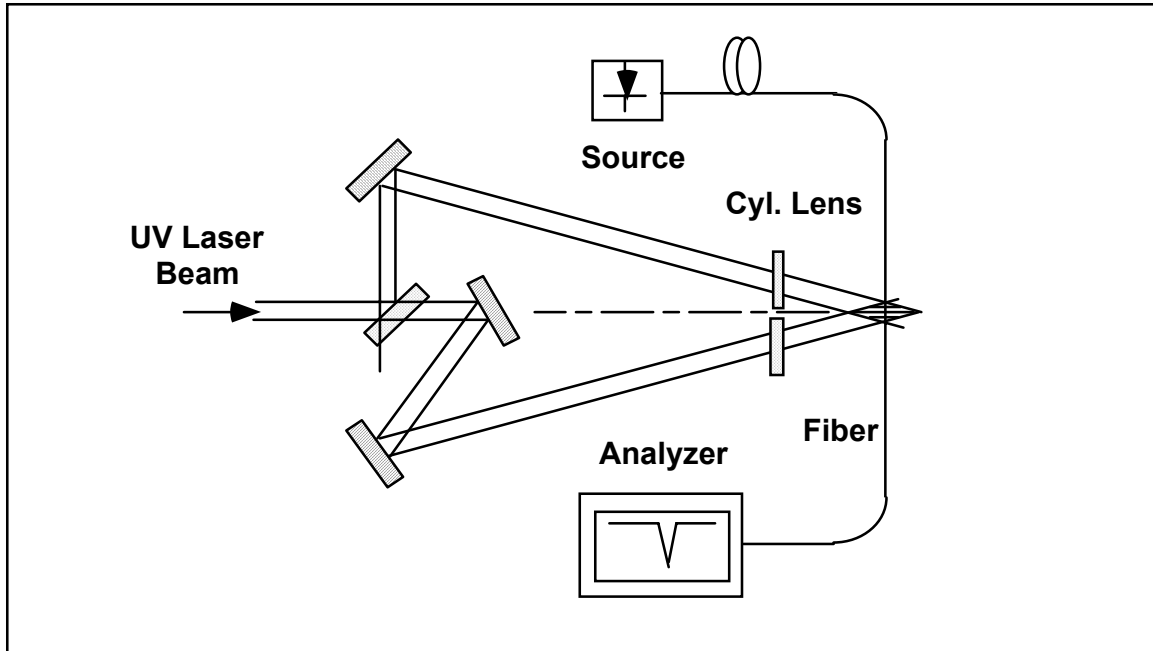

Figure 3.2 Two-beam interferometer for writing fiber Bragg gratings

Diffractive optical element phase mask technique

The laser beam illuminates the fiber through a phase mask. This mask is a binary grating with a groove profile and depth optimized to diffract most of the incident UV laser energy into the plus and minus first diffraction orders while minimizing energy in the zero and higher orders (see Fig. 3.3)

The phase mask schemes require fewer components, alignment is easy, and the experimental set-up is less sensitive to ambient vibrations. However the phase-mask-based techniques are wavelength specific for a particular mask even though straining the fiber before exposure does permit a limited tuning range.

For a resonance wavelength near 1550 nm in standard telecommunication fibers, the phase mask grating period is near 1 μm (groove width of 0.5 μm), while the groove depth is between 200 and 300 nm, depending on the wavelength of the UV light source. By changing the groove size (width and / or depth) of a fixed period grating, the relative intensity of the first-order diffracted beams can be varied, thereby changing the fringe contrast and the amplitude of the photoinduced refractive index modulation. Variable diffraction efficiency phase masks can be fabricated by direct writing in silica with a focused ion beam, followed by differential wet etching as described in References [6,7].

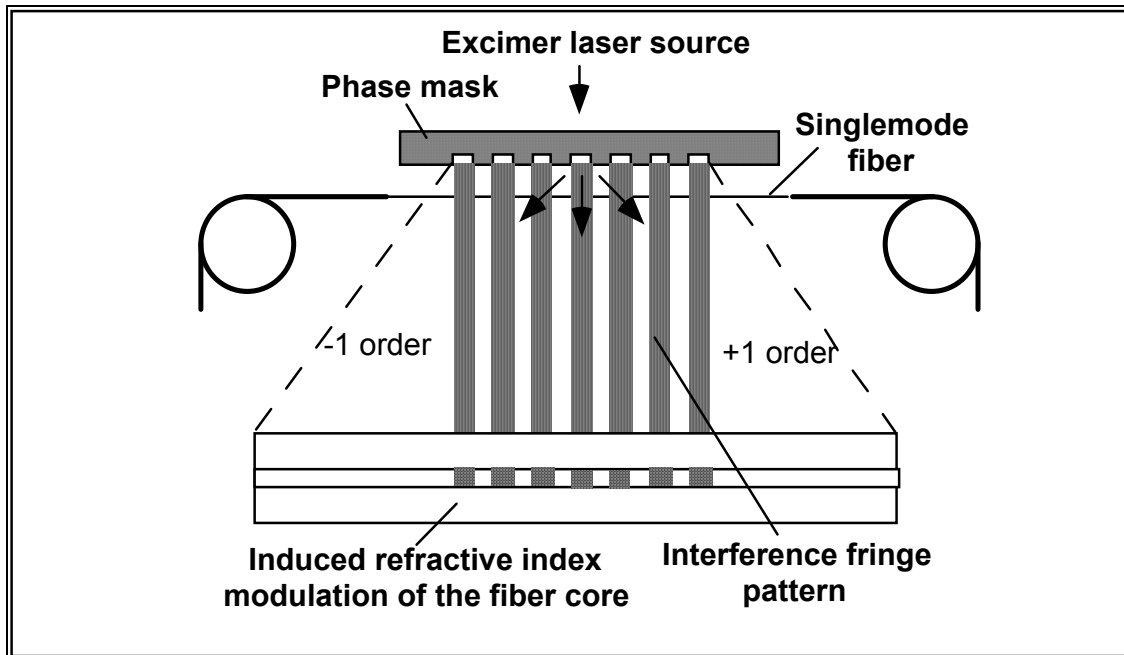

Figure 3.3 Phase mask technique for writing fiber Bragg gratings

Point-by-point method

Short length Bragg gratings have been made using the point-by-point fabrication technique by single excimer laser pulse irradiation. Each element of the grating is written by imaging a slit on the photosensitive fiber core and then using a single laser pulse to illuminate the slit at normal incidence.

The point-by-point technique is very flexible, thereby permitting the fabrication of gratings with a variety of different lengths, grating periods and spectral responses. Difficulties intrinsic to the point-by-point writing process are associated with the need to align and translate the fiber through the image plane of the slit. In single pulse writing with a focused light beam, photoinduced index changes occur only in the focal region where the light intensity is above a fairly sharply defined threshold. Therefore, the size of the region in which the refractive index changes occur can be smaller than the spot size of the focused light beam.

The point-by-point method is straightforward and not wavelength specific. However, it is typically less accurate than the other techniques.

Photosensitivity enhancement techniques: hydrogen loading

Grating formation is generally dependent on the existence of Ge related defects which can vary significantly from fiber to fiber. Nevertheless index changes of up to 1.2×10^{-3} have been reported for low GeO₂ fibers [8]. Alternatively, it has been shown that strong gratings can be formed in a single intense excimer laser pulse, by inducing physical damage in certain fiber types [9]. In general, it has not been possible to generate large and reproducible index changes in an arbitrary chosen fiber. Typically, UV induced index changes have been limited to $\sim 3 \times 10^{-5}$ for standard single-mode fibers doped with 3% Germania. Enhancing the fiber photosensitivity has generally required increasing the GeO₂ doping level or exposing the fiber or preform to reducing conditions at high temperatures.

Lemaire et al [10] reported a technique which can sensitize fibers using a low temperature hydrogen treatment prior to the UV exposure. This hydrogen loading is carried out by diffusing H₂ molecules into fibers at low temperatures and high pressures. Subsequent exposure to UV or intense heat (e.g. a flame or CO₂ laser) causes the dissolved H₂ to react in the glass, typically at Ge sites, resulting in large permanent index changes in the fiber core. This technique is applicable to any GeO₂ doped fiber, and does not require the use of fibers made with high dopant levels or other special processing.

Apodisation of the spectral response of fiber Bragg gratings

The main peak in the reflection spectrum of a finite-length Bragg grating with uniform modulation of the index is accompanied by a series of sidelobes at adjacent wavelengths. It is important to lower the reflectivity of these sidelobes, or apodise the reflection spectrum of the grating in devices where high rejection of the nonresonant light is required (dense wavelength division multiplexing in multiplexed sensors, for instance). In practice, apodization is accomplished by varying the amplitude of the coupling coefficient along the length of the grating.

For short-period gratings fabricated in optical fibers by laser sidewriting techniques, a method used to apodise the response consists in exposing the optical fiber with the interference pattern formed by two non-uniform ultraviolet light beams [11]. In the phase mask technique, apodisation can also be achieved by varying the exposure time along the length of a grating, either by a double exposure [12] or by scanning a small writing beam [11]. In all these apodization techniques, the variation in coupling coefficient along the length of the grating comes from local changes in the intensity of the UV light reaching the fiber. These changes also induce a variation in the average refractive index and effectively chirp the grating response unless compensation measures are taken.

Another apodization technique [13] is based on exposing the fiber to a uniform UV beam transmitted through a phase mask with non-uniform diffraction efficiency. One advantage of this method is reproducibility, because the envelope of the UV fringe pattern reaching the fiber is determined by the design of the phase mask alone. Another advantage is that there is no induced chirp (in the regime where index changes are proportional to UV dose) because the total average UV fluence reaching the fiber is uniform along the grating length.

Long-term stability and reliability

A stringent and thorough mechanical and optical qualification testing of FBGs has been conducted by 3M. The results of their program are summarized in reference [28]. This clearly shows that, with proper fiber selection, UV exposure and pre-annealing, it is possible to obtain stable gratings over many years at temperatures below 400 C.

Interrogation Methods

In this section we will briefly discuss the ways in which optical fiber Bragg grating sensors can be individually interrogated and collectively multiplexed in order to be able to perform multi-point sensing.

Due to the wavelength-encoded nature of the signals in optical fiber Bragg gratings (FBG), there are no problems associated with transmission or bending losses in the fiber. Furthermore, their intrinsic nature and all-fiber constructions allows for in-line arrays of several Bragg gratings in a single fiber. This makes it possible to have multi-point, as well as quasi-distributed sensing.

Wavelength Division Multiplexing (WDM)

FBG elements are ideally suited for multiplexed networks since each grating is written at a unique wavelength. Consequently, it is possible to interrogate each FBG sensor in an intermittent fashion without the need for re-calibration. Furthermore, since each output signal is wavelength encoded, their use lends naturally to wavelength division multiplexing techniques (WDM). In this configuration each FBG is assigned a given "slice" of the input broad-band light spectrum. Care must also be maintained to avoid overlapping of distinct FBG's spectra.

Fig. 3.4 depicts a generic arrangement for the interrogation of several FBGs based on WDM in the reflection mode. The specific Bragg wavelength shifts of each FBG can be determined, practically in real time, by coupling light from a broadband source such as an edge-emitting LED or a superluminescent solid state or fiber source. The returned signal can be analyzed using an optical spectrum analyzer, a Fabry-Perot tunable filter, a color glass filter, etc. In order to improve the signal-to-noise ratio and the wavelength resolution, Kersey et al [29] used a zero crossing detection scheme, whereby the detected reflected signal is differentiated thus converting the peak wavelength from a given FBG, into a zero signal level in the differentiated waveform. With this technique it is possible to obtain better than 3 μ strain resolution.

Today, most popular WDM interrogators use fast sweeping laser as a light source instead of a broadband source. The advantages are longer range (due to higher source power) and greater sensor capacity (due to the wider wavelength windows of 50 to 100nm) and the ability to simultaneously interrogate many fibers each with dozens of sensors.

Time Division Multiplexing (TDM)

A further increase in the number of sensors per fiber that can be interrogated is possible using time division multiplexing techniques (TDM) in combination with WDM. This scheme is illustrated in Fig. 3.5.

In this approach, the spectrum of the source is used multiple times to scan separate groups of FBGs in time. If a short duration pulse of light from the broadband source is launched into this system, the reflections from the FBGs at every point in the array, will return at the detector at increasingly later times depending on how farther away they are to the detector itself. If the detector is synchronized and time-gated, it is possible to selectively interrogate a given FBG array in time for a given wavelength window.

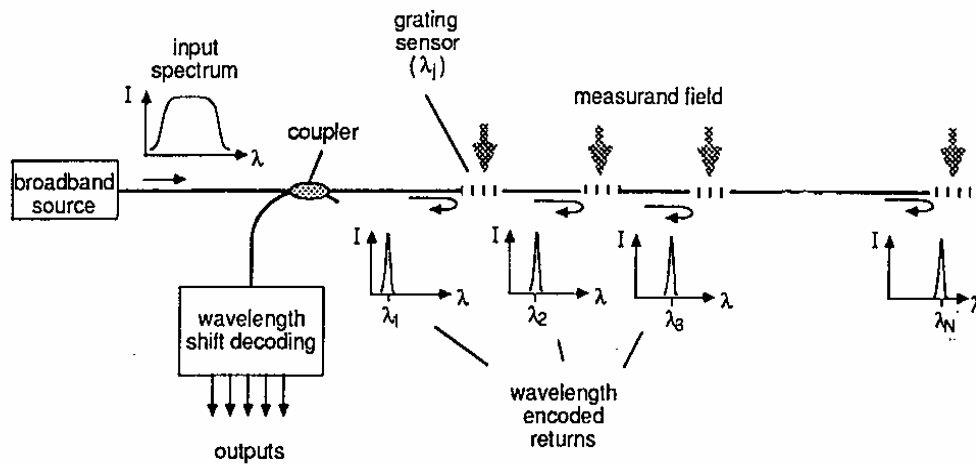

Figure 3.4 Schematic representation of a WDM interrogation of a FBG array

This approach has been demonstrated to interrogate up to 60 different FBGs [30], by scanning five arrays with 12 gratings each. The system used a tunable Fabry-Perot filter as the wavelength selector. The system is capable of handling even larger number of gratings by expanding the number of arrays that can be sequentially addressed. Drawback of this type of implementation is the limited scanning frequency, which would limit the response of the system to dynamic signals and transients, and limited spectral resolution. FBGs can be spaced no closer than 1 meter for the even the best TDM systems.

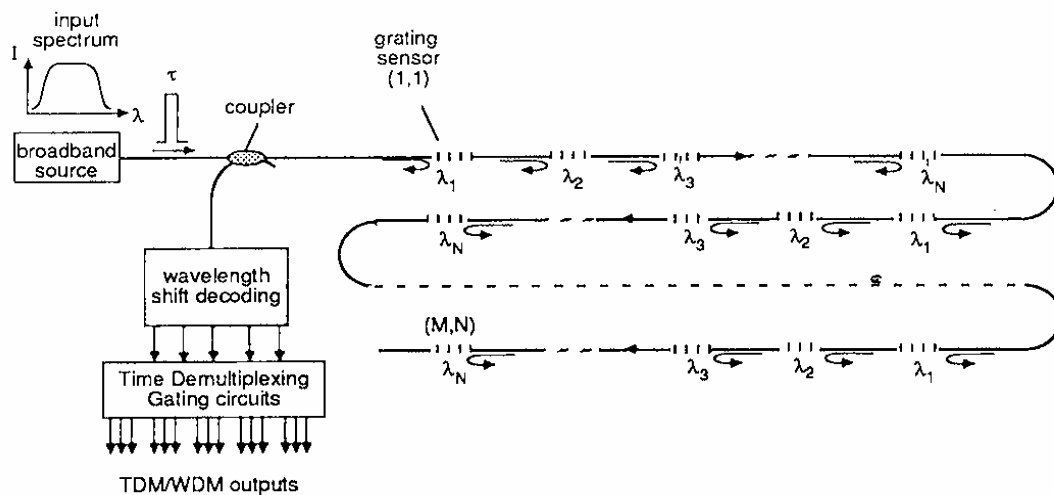

Figure 3.5 Aspect of a time-multiplexed WDM interrogated FBG sensor array

Another drawback of the TDM technique, when combined with Bragg gratings, is that of cross-talk [31]. There are two sources for cross-talk: multiple reflections and spectral shadowing. Multiple reflection cross-talk arises from the delay introduced into a reflected light signal upstream that has undergone multiple reflections during its travel and has effectively overlapped in time with the reflected signal of a grating downstream. The effect is proportional to the grating's reflectivity and can be minimized using low reflectivity gratings (<5%). In fact, the number of grating elements that can be interrogated under a given signal-to-noise ratio will depend on the amount of cross talk. Hence, the pairing of low-reflectivity gratings with high sensitivity detection will be essential to interrogate large arrays of gratings.

The spectral shadowing cross-talk is the distortion introduced in the reflected spectrum of a downstream grating resulting from the double pass of the incoming light through an upstream grating.

The above deleterious effect can be eliminated by staggering the grating arrays to avoid spectrum overlaps by having arrays branching off instead of serially connected. To reduce time overlaps and cross-talk the time interval between gratings can be increased by adding passive delay lines. These measures can be implemented at the expense of additional components such as fiber couplers, delay lines and stronger reflectivity FBGs.

Strain Sensing

Fiber Bragg gratings are often used in either strain or temperature sensing, especially where environments are harsh (e.g., high-EMI, high-temperature or highly corrosive). It is also possible to use fiber Bragg gratings to sense other environmental parameters such as pressure chemical reaction by using an additional transducer instead of using Fiber Bragg grating itself.

Fiber Bragg Grating Mounting Practice

To attach the fiber Bragg Grating to the structure in question you would use the best adhesive for this application. For example, in a high temperature environment, you would have to be sure you use an epoxy that would be best for this application. The first step in this process is to condition the surface, such as to sand it smooth, and to neutralize the surface so that it has proper pH he would and epoxy the fiber Bragg Grating to the surface using any number of autopsies that would be best applicable. Once the sensor is glued to the structure in the field it is very important to protect the fiber from damage.

This can often be very challenging due to the distance that the structure may be from the measurement instrumentation. Fortunately there are a number of excellent cabling methods for optical fiber, such as Kevlar wrap or even metallic sheathing for optical fiber. These types of cabling would be best for industrial settings where there is a large amount of the equipment being moved around and cables are being run over the floor which can make them susceptible to a large amount of traffic damage. For aircraft applications, quite the opposite may be true. It is very important in these applications to use optical fiber sheathing which is very low in weight so as not to lose the advantages that optical fiber has as being a very light weight sensor.

Long-term Static Strain Sensing

Long term static strain testing is very easy to accomplish with fiber Bragg gratings and due to their inherent self-referencing. Self-referencing is the ability to have a starting point. Each Bragg grating has an associated zero strain wavelength. It is important to remember that when purchased, the fiber Bragg grating may have a specific center wavelength at rest. However, when it is attached to a structure, the process of attaching the fiber Bragg Grating to structure will alter its shape. Therefore, the Zero Strain point of the fiber Bragg Grating must be reevaluated after it is the attached to the structure in question. The internal forces in the glue used to attach the fiber Bragg Grating Structure will cause strain within the fiber Bragg Grating. So after the fiber Bragg

Grating is attached to the structure, it is allowed to come to a steady state and then the user then determines the zero point before the test is begun. This steady state, such as at room temperature, becomes the initial point for the fiber Bragg grating testing. During the test we monitor the reflective wavelength of the fiber Bragg grating, and then compare it to the initial wavelength that was measured. That gives you the measurement of what is happening to that structure over time.

For a long-term static strain test you are interested in measuring the long-term static strain of the component in question. We would mount the grating on that structure; find out what the initial wavelength is, then allow a set amount of time to pass. We can return to the structure, reattach and refer back to the initial wavelength. That would give you the determination of what this strain is from the initial condition at that time. This is in contrast with electrical strain gauges and other types of instruments where we would have to constantly monitor the changes in the sensor itself, whether it is resistance change, a capacitance change, or other electrical change. With an electrical Strain gauge, you do not have the ability to disconnect your Monitoring instrumentation as is possible with a fiber Bragg test. The reason for this is that with electrical strain gauges you have to balance out the gauge each time you connect your resistance Strain gauge to it. This is a very great advantage of Fiber Bragg gratings, the ability to return to them after a large amount of time such as months or even years.

For example we may want to test the strain that is occurring over time in number of bridges. If we have sufficient resources, we can use one set of instrumentation per bridge. We can set this instrumentation to take one data point of the fiber Bragg Grating per hour, per day, or per week. However, if we are responsible for testing 100 bridges then it is not economical to buy 100 sets of instrumentation. We can use this one set of instrumentation to test each of these 100 bridges on a monthly cycle. Presently, in the case of bridges, it is much more common for an engineer to visit the bridge and conduct impact testing using an impact hammer on several different parts of the bridge. This is very time-consuming and possibly hazardous due to the height of some bridge structures. It would be much more efficient to attach a number of fiber Bragg grating sensors throughout the bridge, attach the instrumentation to this bridge on a periodic basis, and conduct all the testing within a matter of moments. Besides bridges, other examples of using fiber Bragg gratings for long-term Static Strain Testing would be buildings, piers, and structures in high earthquake prone areas.

Dynamic Strain Sensing

Most earthquakes and other earth tremors are low frequency events. Fiber Bragg gratings can be attached to structures and monitored for the vibrations during earth tremors and earthquakes. Another application would be the connection of fiber Bragg gratings to piers and other shore structures to determine their Vibration during the ebb and flow of tides. Another example of very low frequency dynamic strain testing would be the reaction of high-rise buildings to wind.

In addition to the very low frequency modes that the structures may have, they may also have higher frequency modes due to the effects of wind and tide. Dynamic strain testing appropriate to the 25 Hz region can also be performed on transportation vehicles such as automobiles, trains, and airplanes. The understanding of the vibrations on the outside of these vehicles can help engineers to dampen the amount of noise and vibration that enters their interiors. These methods can also be used to lessen the effects of fatigue on the vehicle structures. Fatigue is an example of how fiber Bragg gratings can be used for Dynamic Strain Testing in addition to long-term Static Strain Testing. Here we would be interested in not only the momentary vibrations undergone by the structures but also in the effects of these vibrations on their long-term strain of the metallic surfaces.

In addition to civil structures and vehicles, there are a number of other applications for Dynamic Strain Testing and Vibration stress testing using fiber Bragg gratings. Fiber Bragg gratings can be attached to industrial machinery to determine the frequency and amplitude of the stress

vibrations. For example, if we are machining metal, it is important to know the rate at which we can machine this object without subjecting it to excess of forces and vibrations. We can attach a fiber Bragg grating on a tool to determine how it is straining due to the applied load. Previously, expert machinists would know how much load to apply it to their machine by feeling for the amount of vibration, or the Vibration signatures. This can all be accomplished by attaching a fiber Bragg Grating to either the machine tool or the object being machined. The vibration signature of either piece can then be determined in used in a feedback loop to be sure that the correct amount of load is applied at all times during the machining process.

Temperature and Pressure Sensing

Using fiber Bragg gratings for temperature and Pressure Sensing follows generally same procedures for long-term Static and Dynamic Strain Testing. We want to be sure that we are not coupling our temperature reading with our strain reading. The idea there is to come up with some way to isolate your fiber Bragg Grating that is being used for temperature testing from any affects of strain on the structure being tested. This is also true to isolate your fiber Bragg Grating from other environmental effects that may be occurring. It may be possible to loosely loop the fiber Bragg Grating to the structure in order to prevent the effects of strain being transferred to the fiber Bragg Grating. It may also be possible to use another structure to carry the strain and prevent it from being transferred to the fiber grating. It may be difficult to accomplish this without also preventing the transference of temperature to the fiber grating. It may be possible to put the fiber Bragg grating on the absolute end of the fiber and glue it down only at one point so that it is hanging loose and not susceptible to the effects of strain. In this way we can see the fiber Bragg Grating being similar to a thermocouple in that it is attached only at one end to the structure.

An example of this would be to record the temperature during the cure process of fiberglass composite pressure vessels. To use a fiber Bragg Grating this way it would be implanted within the fiberglass composite to measure the temperature change during the curing process. Fiber Bragg gratings can also be used to measure temperature changes in a caustic chemical environment where would not be possible to use a metallic Strain gauge. It is possible to use a thermocouple in these environments, however the disadvantage of the thermocouple is that there may be transference of heat along the middle of the thermocouple, and additionally it is easier to embed fiber Bragg gratings within a structure.

For pressure applications it is important to remember that fiber Bragg gratings are mostly for measuring temperature and Strain Testing. Therefore for measuring Pressure applications it is often best to mount the fiber Bragg Grating to a diaphragm, or to use the fiber itself as a Pressure transducer so that the Pressure in the environment is being more directly transferred to the core of the fiber where the grating resides. In this latter application the Pressure is acting upon the fiber grating so as to produce a three-dimensional strain mode.

Fiber Bragg gratings are commonly used for temperature and Pressure Sensing in the oil and gas drilling industries. Fiber gratings can be used for monitoring temperature and pressure in the interior walls of oil wells.

Magnetic and Electric Field Sensing

It is possible to coat an optical fiber Bragg Grating with a ferro-electrical coating. This coated fiber Bragg Grating is then placed in an electromagnetic field, in the field in causes this coated grating to expand or contract.

Chemical Sensing

It is possible to coat a fiber Bragg Grating so that the coating induces a strain within the fiber Bragg grating in proportion to the chemical reaction. For example is possible to coat the fiber Bragg grating with palladium and use that to monitor hydrogen production. Palladium absorbs

hydrogen, so as the level of hydrogen in the outside environment increases the Palladium expands causing a strain on the fiber. This process is reversible so as hydrogen leaves the air, the Palladium degasses and the fiber Bragg Grating then returns to its normal shape.

The fiber Bragg Grating can be coated with another type of reactive material that will react only to the chemical in question. This is especially applicable in cases of bio agents where the absorption of the bio agent by the coating on the fiber Bragg Grating would cause the grating to expand in proportion to its Absorption of the bio agent. It is also possible that the absorption of the bio agent by the coating on the fiber Bragg grating would cause a change in the index of refraction of the fiber Bragg grating which could then be determined by the measuring instrument.

IV. Optical Fiber Fabry-Perot Sensors

Fiber optic Extrinsic Fabry-Perot Interferometric (EFPI) sensors have been the focus of intense research during the last ten years. A number of sensor configurations, highly sensitive to temperature, mechanical vibration, acoustic waves, and magnetic fields have been reported in the literature [32].

Kersey et al. were among the first to demonstrate such a sensor where the FP cavity was created by the use of air-glass interfaces at the fiber ends as the reflectors [33]. Murphy et al. demonstrated a quadrature phase-shifted sensor for the detection of the amplitude and the relative polarity of dynamically varying strain [34]. In most of these sensor configurations, the maximum temperature of application is limited by the temperature at which the silica fiber begins to soften (~ 1000 °C). This prohibits the use of the use of these sensors in harsh environments involving high temperatures and large working stresses.

Sapphire fiber is an ideal candidate for use in these harsh environments. The last few years have seen a growing interest in using sapphire fibers for high temperature sensing. A sapphire rod-based high-temperature sensor was demonstrated by Dils et al [35]. In this sensor, platinum with a high melting point was deposited onto the fiber tip to serve as a blackbody radiator. The measured temperature information was extracted by taking the ratio of two specifically selected wavelengths emitted by the blackbody. Later, Murphy et al. proposed and demonstrated single crystal sapphire-rod based fiber EFPI sensor for measurement of temperature and acoustic waves [36]. The authors have previously demonstrated a sapphire fiber-based intrinsic Fabry-Perot sensor (IFPI) for measuring temperatures above 1000°C. Wang et al., have demonstrated a high temperature sensor that is based on the birefringence of the sapphire rod [37]. The disadvantage of using the sapphire fiber/rod as a Fabry-Perot is that the sensor performance is very sensitive to the phase noise of the source, which can be eliminated by using an air-gap cavity of very short length.

Principle of the Extrinsic EFPI Fiber Sensor

The schematic of a typical EFPI sensor configuration is shown in Figure 4.1 Light from a laser propagates along a lead-in single mode fiber to the Fabry-Perot cavity which is formed by the input/output and target fibers. A fraction (approximately) four percent of this incident light is reflected at the output end face of the input/output fiber and returns directly back down the fiber. The light transmitted out of the input/output fiber projects onto the fiber end face of the target fiber. This reflected light from the target fiber is partially re-coupled into the input/output fiber. Interference between the two reflections then gives rise to interfering fringes.

The detected photodiode signal current may be shown to be proportional to the phase difference between the two reflected optical fields. Assume a coherent, approximately plane wave detected

at the output of the sensor. This wave can be represented in terms of its complex amplitude $U_i(x, z, t)$, given by

$$U_i(x, z, t) = A_i \exp(j\phi_i), \quad i = 1, 2, \quad (1)$$

Where the variable A_i can be a function of the transverse coordinate x and the distance traveled z and the subscripts $i = 1, 2$ stand for the reference and the sensing reflections, respectively. Assuming that the reference reflection $A_1 = A$, the sensing reflection coefficient A_2 can be approximated by the simplified relation

$$A_2 = A \left\{ \frac{ta}{a + 2s \tan[\sin^{-1}(NA)]} \right\}, \quad (2)$$

where a is the fiber core radius, t is the transmission coefficient of the air-glass interface (~ 0.98), s is the end separation, and NA is the numerical aperture of the single-mode fiber, given by $NA = (n_1^2 - n_2^2)^{1/2}$. n_1 and n_2 are the refractive indices of the core and the cladding, respectively. The observed intensity at the detector is a superposition of the two amplitudes and is given by

$$I_{\text{det}} = |U_1 + U_2|^2 = A_1^2 + A_2^2 + 2A_1A_2 \cos(\phi_1 - \phi_2), \quad (3 a)$$

which can be rewritten as

$$I_{\text{det}} = A^2 \left(1 + \frac{2ta}{a + 2s \tan[\sin^{-1}(NA)]} \cos\left(\frac{4\pi s}{\lambda}\right) + \left\{ \frac{ta}{a + 2s \tan[\sin^{-1}(NA)]} \right\}^2 \right), \quad (3 b)$$

where we have assumed that $f_1 = 0$ and $f_2 = 2s(2\pi/\lambda)$, and λ is the wavelength of operation in free space.

The simplified loss relation in Equation 3b is sufficient to understand the operation of the EFPI sensor. Exact analysis has been performed using the Kirchhoff's diffraction formalism. Changes in the separation distance s between the surfaces of the fibers aligned in the support tube produce a modulation of the output signal current. This modulation is sinusoidal, gradually decreasing in amplitude as s increases.

The real-time monitoring of changes in the phase of the output fringes will thus yield information in the air-gap separation between the end faces of the two fibers in the sensor head.

Owing to the high sensitivity of the fringe phase to the air-gap, the basic EFPI sensor geometry or its variations may therefore be extremely attractive to the measurement of a large variety of measurands which can be related to microdisplacement.

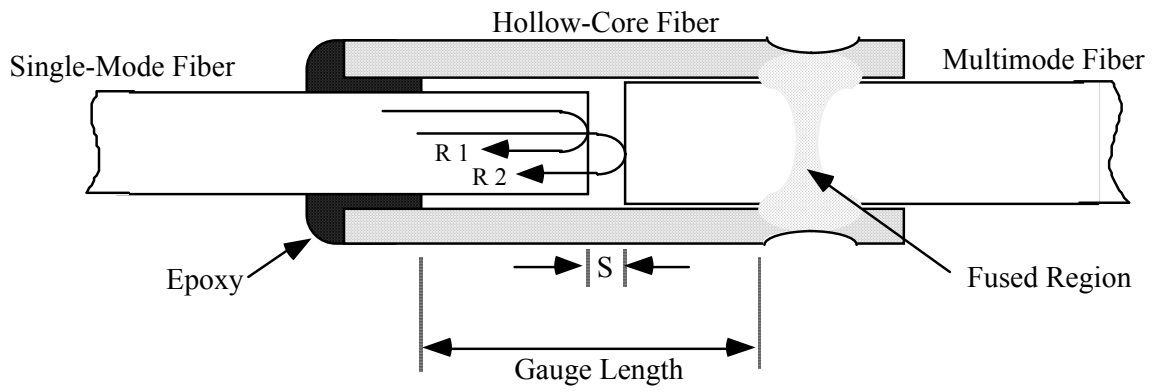

Figure 4.1 Aspect on an Extrinsic Fiber Fabry-Perot Interferometer sensor

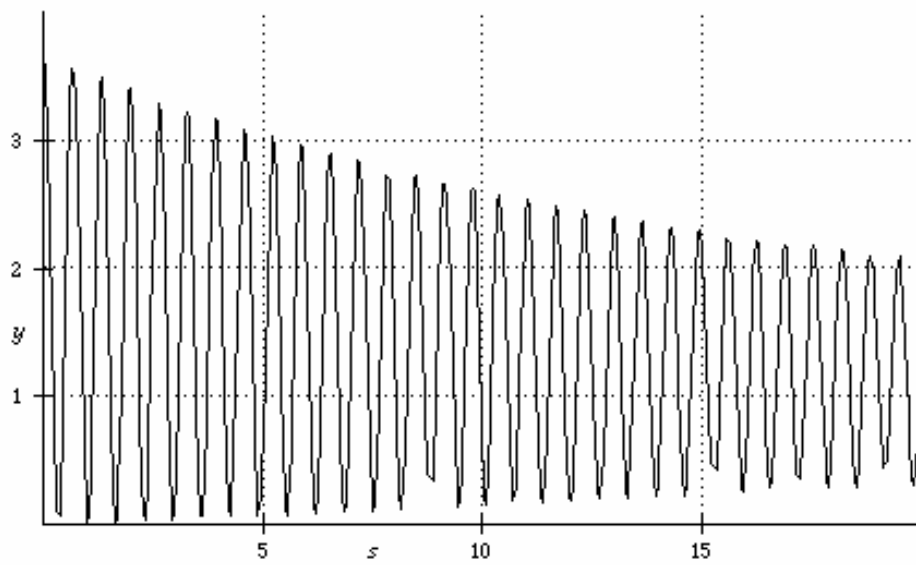

Figure 4.2.- EFFI light response signal as a function of fiber separation S

V. References

- 1 Hill K.O. et al.: Photosensitivity in optical fiber waveguides: Application to reflection filter fabrication, *Appl. Phys. Lett.*, 1978, 32, pp 647 - 649.
- 2 Meltz et. al.: Formation of Bragg gratings in optical fibers by transverse holographic method, *Opt. Lett.*, 1989, 14, pp. 823 -825.
- 3 Hand D. P. et al., *Opt. Lett.*, 25, 1990, p 102.
- 4 Sceats et al., *Annu. Rev. Mater. Sci.*, 23, 1993, p 381.
- 5 Bernardin et al., *Opt. Commun.* 79, 1990, p 194.
- 6 Albert J. et al.: Maskless writing of submicron gratings in fused silica by focused ion beam implantation and differential wet etching, *Appl. Phys. Lett.*, 1993, 63, pp 2309 - 2311.
- 7 Albert J. et al.: Fabrication and characterization of submicron gratings written in planar silica glass with a focussed ion beam, *Int. Symp. on Integrated Optics, Proc. SPIE*, 1994, 2213, pp 78 - 88.
- 8 Limberger et al.: Spectral characterization of photoinduced high efficient Bragg gratings in standard telecommunication fibers, *Electron. Lett.*, 1993, 29, pp 47 - 48
- 9 Archambault et al.: 100% reflectivity Bragg reflectors produced in optical fibers by single excimer laser pulses, *Electron. Lett.*, 1993, 29, pp 453 - 455.
- 10 Lemaire P.J. et al.: High pressure H₂ loading as a technique for achieving ultrahigh UV photosensitivity and thermal sensitivity in GeO₂ doped optical fibers, *Electron. Lett.*, 1993, 29, pp. 1191 - 1193.
- 11 Martin J et al.: Novel writing technique of long and highly reflective in-fiber gratings, *Electron. Lett.*, 1994, 30, pp 811 - 812.
- 12 Hill K.O. et al.: Bragg gratings fabricated in monomode photosensitive optical fibers by UV exposure through a phase mask, *Appl. Phys. Lett.*, 1993, 62, pp 1035 - 1037.
- 13 Albert J. et al.: Apodisation of the spectral response of fiber Bragg gratings using a phase mask with variable diffraction efficiency, *Electron. Lett.*, 1995, 31, pp 222 -223.
- 14 Byron K. C. et al.: "Fabrication of chirped fiber gratings by novel stretch and write technique", *Electron. Lett.*, 1995, 31, pp 60 -61.
- 15 Othonos et al.: Superimposed multiple Bragg gratings, *Electron. Lett.*, 1994, 30, pp 1972 - 1974.
- 16 Morey W. et al., "Recent Advances in Fiber Grating Sensors for Utility Industry Applications", *Proc. SPIE* vol. 2594, 1995.
- 17 Kashyap, R., "Photosensitive Optical Fibers: Devices and Applications", *Op. Fiber Tech.*, Vol. 1, pp 17-34, 1994.
- 18 Bennion, I. Et al., "UV-Written In-Fibre Bragg gratings", *Opt. Quant. Elect.*, Vol. 28, pp 93-135, 1996.
- 19 More, W.W., "Fiber Optic Grating Technology", *SPIE Proc.*, Vol. 2574, pp 22-31, 1996.
- 20 Morey, W.W., Meltz, G., and Glen, W.H., "Fiber Optic Bragg Grating Sensors", *SPIE Proc.*, Vol. 1169, pp 98-107, 1989.
- 21 Meltz, G., "Overview of Fiber Grating-Based Sensors", to be published, *SPIE Proc.*
- 22 Archambault, L., Reekie, L., and Russell, P. J., "100% Reflectivity Bragg Reflectors Produced in Optical Fibers by Single Excimer Laser Pulses", *Elect. Lett.*, Vol. 29, pp 453-455, 1993.
- 23 More, W.W., "Development of Fiber Bragg Grating Sensors for Utility Applications", *EPRI Report TR-105190*, September 1995.
- 24 Williams, D.L. and Smith, R.P., "Accelerated Lifetime Tests on UV written Intra-Core Gratings in Boron Germania Codoped silica Fibre", *Elect. Lett.*, 25 September, 1995.
- 25 Varelas, D., Limberger, H.G., and Salathe, R.P., "Enhanced mechanical performance of singlemode optical fiber irradiated by a CW UV laser", *Elect. Lett.*, Vol. 33, No. 8, pp70-705, 1997.
- 26 Espindola, R. et al., "Fiber Bragg Gratings Written Through a Fiber Coating", *OFC 1997 Conference*, Post deadline # PD4-1, 1997.
- 27 Dianov, E.M. et al., "Refractive-index Gratings Written by Near-ultraviolet Radiation", *Opt. Lett.*, Vol. 22, No. 4, pp 221-223, 1997.

- 28 Minnesota Mining Co., "Fiber Bragg Gratings Application Note: The mechanical and optical reliability of fiber Bragg gratings", Feb. 1996.
- 29 Kersey, A. D., Berkoff, T. A., and Morey, W. W., "Multiplexed Fiber Bragg Grating Strain-Sensor System with a Fiber Fabry-Perot Wavelength Filter", Opt. Lett., Vol. 18, No. 16, pp 1370-1372, 1993.
- 30 Davis, M.A., Bellemore, D.G., Putnam, M.A., and Kersey, A.D., "Interrogation of 60 Fibre Bragg Grating Sensors with Microstrain Resolution Capability", Elect. Lett., Vol. 32, No. 15, pp 1393-1394, 1996.
- 31 Morey, W.W., Dumphy, J.R., and Meltz, G., "Multiplexing Fiber Bragg Grating Sensors", SPIE Proc. Vol. 1586, pp 216-224, 1991.
- 32 T. Yoshino, K. Kurosawa, K. Itoh, and T. Ose, IEEE J. Quantum Electron. QE - 18, 1624 (1982).
- 33 A. D. Kersey, D. A. Jackson, and M. Corke, Opt. Comm. **45**, 71 (1983).
- 34 K.A.Murphy, M.F.Gunther, A.M.Vengsarkar, R.O.Claus, " Quadrature phase shifted, extrinsic Fabry-Perot optical fiber sensors", Optics Letters, **16(4)**, 1991, pp273-275.
- 35 R. R. Dils, J. Appl. Phys. 84, 1198 (1983).
- 36 K.A.Murphy, S.L.Feth, A.M.Vengsarkar and R.O.Claus "Sapphire rod-based EFPI sensor for high temperature measurement," Proc. of SPIE, 1588 (1991)
- 37 Anbo Wang, S.Gollapudi, K.A.Murphy, R.G.May, and R.O.Claus, "Sapphire fiber-based Intrinsic Fabry-Perot Interferometric (IFPI) sensor", Optics Letters, **14(17)**, 1021 (1992)

VI. Suggested Bibliography

Nondestructive Testing of Concrete Elements and Structures,

Edited by Farhad Ansari and Stein Sture, American Society of Civil Engineers, 1992.
ISBN 0-87262-887-6. 229 pp.

Applications of Fiber Optic Sensors in Engineering Mechanics

Edited by Farhad Ansari, American Society of Civil Engineers, 1993.
ISBN 0-87262-895-7. 230 pp.

Handbook on Structural Testing

Edited by Robert T. Reese and Wendell A. Kawahara, SEM & The Fairmont Press, 1993.
ISBN 0-88173-155-2

Fiber Optic Smart Structures

Edited by Eric Udd, John Wiley & Sons Inc., 1995.
ISBN 0-471-55448-0 671 pp.

Smart Structures and Materials

Brain Culshaw, Artech House, 1996.
ISBN 0-89006-681-7. 207 pp.

Strain and Temperature Measurement with Fiber Optic Sensors

Regis J. Van Steenkiste and George S. Springer, Technomic Publishing Co, 1997.
ISBN 1-56676-480-7. 294 pp.

Fiber Optic Sensors for Construction Materials and Bridges

Edited by Farhad Ansari, Technomic Publishing Co., 1998.
ISBN 1-56676-671-0. 267 pp.

Structural Monitoring with Fiber Optic Technology

Raymond M. Measures, Academic Press, 2001.
ISBN 0-12-487430-4. 716 pp.

Handbook of Optical Fibre Sensing Technology

Edited by Jose Miguel Lopez-Higuera, John Wiley & Sons Inc., 2002.
ISBN 0-47182-053-9. 828 pp.