

Applications

- **Spectrum Sliced Source**
- **ITU Filter**
- **Calibrated Wavelength Reference**
- **Laser Stabilization**
- **WDM Emulation**
- **Optical Sensing**

Features

- **Uniformly spaced transmission peaks**
- **Small footprint**
- **Vibration and shock resistant**
- **Low loss**
- **No alignment required**

Description

The **Micron Optics FFP-I**, Fiber Fabry-Perot Interferometer family of products is based on a fixed interferometer design with smooth, uniformly spaced transmission peaks. The **FFP-I** consists of a lensless plane Fabry-Perot Interferometer with a single-mode optical fiber waveguide between two highly reflective multilayer mirrors. The **FFP-I** is manufactured with fiber pigtails so no alignment or mode-matching is required. The distances between peaks (FSR) may be fit exactly to customer specifications and a TEC package is available for thermal stability and minor adjustments of the bandpass frequency or wavelength.

FFP-I

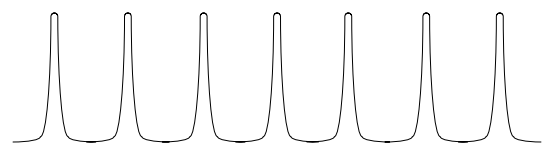



FFP-ITU

An FFP-ITU is a specially constructed FFP-I that aligns to the International Telecommunications Union (ITU) grid with 25, 50 or 100 GHz spacing. Grid spacings are available with tolerances of +/- 0.5%, +/- 0.2%, +/- 0.1% or +/- 0.05% for more exact alignment with the ITU grid. The FFP-ITU has a built-in thermo electric controller (TEC) package for thermal stability, and can be controlled by Micron Optics' TEC Controller.

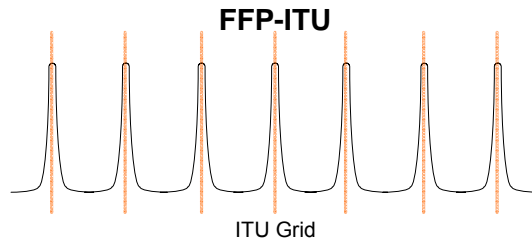

picoWave[®]

The *picoWave[®]* is Micron Optics' patented multi-wavelength reference that enables real time wavelength calibration to picometer accuracy. Combining the uniform spacing of the FFP-I, a wavelength marker of a Fiber Bragg Grating, and a built-in TEC for thermal stability, the *picoWave[®]* makes an ideal calibrated wavelength reference. The FFP-I and FBG can be configured in Series or in Parallel (see diagrams at right).

picoWave (Serial Configuration)

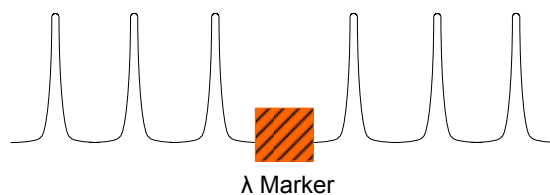

picoWave (Parallel Configuration)

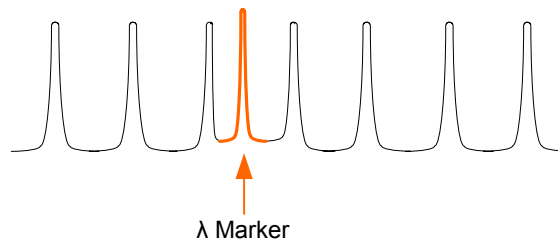

TEC Controller

The Micron Optics *picoWave[®]* Controller is designed to be used in conjunction with Micron Optics' *picoWave[®]*, FFP-ITU and Fiber Fabry-Perot Interferometer (FFP-I), where temperature stability is critical for wavelength reference stability.

Options

- 020 PM Fiber*
- 030 Low Variation Bandwidth*
- 060 FC/SPC Connectors (Fusion Spliced)
- 061 FC/APC Connectors (Fusion Spliced)
- 062 SC/SPC Connectors (Fusion Spliced)
- 063 SC/APC Connectors (Fusion Spliced)
- 065 FC/APC Connectors (Connectorized)
- 069 Other Connectors
- 080 TEC Equipped*

* Please verify specifications with Micron Optics.

Part Number

FFP-I **or**
FFP-ITU

Wavelength Band

- Specify λ Center (ie: 0800 = 800nm)

Bandwidth Unit

- G – GHz
- M – MHz
- K – KHz

Insertion Loss

- Specify loss
- Example: 3.0 = 3.0 dB loss

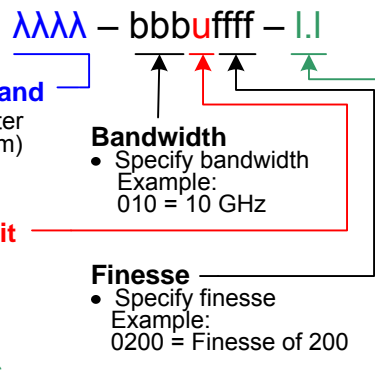

Specifications

Operating Wavelength Range¹

S-Band	1480 – 1520 nm
C-Band	1520 – 1570 nm
L-Band	1570 – 1620 nm

Optical: FFP-I

Free Spectral Range (fixed FSR but selectable within this range)	0.01 – 10,000 GHz (0.08 pm – 80 nm)
Finesse	10, 40, 100, 150, 200, 650, 1000, 2000, 4000
Insertion Loss ² (typical)	3 dB
Thermal Coefficient	~13 pm/°C
Input Power ³	< 100 mW (for F < 200)

Optical: FFP-ITU

Free Spectral Range	25, 50 or 100 GHz (0.2, 0.4 or 0.8 nm)
Finesse	30
Insertion Loss (typical)	3 dB
ITU Tolerance Options	0.5%, 0.2%, 0.1% or 0.05%

Optical: *picoWave*[®]

Free Spectral Range	100 or 200 GHz (0.8 or 1.6 nm)
Finesse	10
Insertion Loss (typical)	3 dB
Wavelength Marker Location	1535 or 1567 nm

Electrical (optional for FFP-I with FSR >10 GHz but <100 GHz, standard for ITU and *picoWave*)

TEC	Melcor Epoxy Filled 04OT2.0-30-F2-EP
TEC Drive Current	<2 A
TEC Qmax (T _H = 25°C)	<4 W
TEC Vmax (T _H = 25°C)	<3.6 V
TEC ΔTmax (T _H = 25°C)	67° C
Thermistor	10 kΩ NTC
Thermal Tuning Wavelength Range (0 – 60 °C)	98 GHz
Thermal Tuning Wavelength Speed (typical)	10 GHz/sec
Wavelength Stability (0 – 60 °C) ⁴	+/-5% of FSR
Wavelength Stability (laboratory conditions) ⁴	+/-1.0 pm (+/-0.125 GHz)
Tuning Resolution	+/-5 pm
FSR Variation over Tuning Range	0.05% of FSR

¹ These are standard center wavelengths with useful spectral range defined by mirror pass band.

² High resolution (BW <2 GHz) FFP-Is are generally polarization sensitive. However, polarization properties are stable and can be adjusted by a polarization controller at the FFP-I input.

³ Maximum input power level depends on finesse value.

⁴ Using Micron Optics *picoWave* Controller.



components

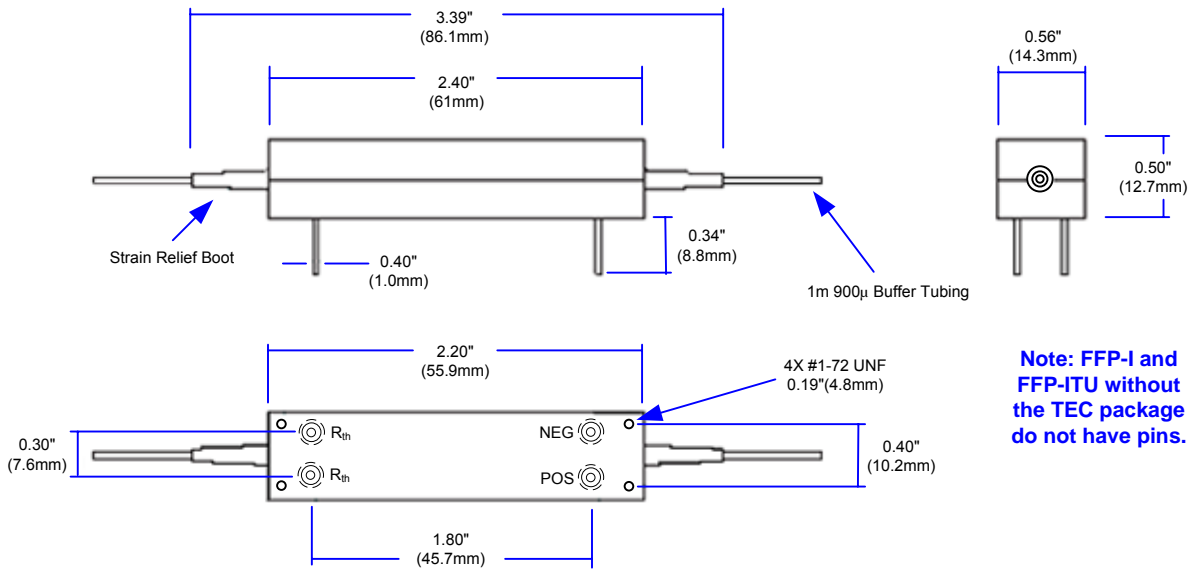

Note: FFP-I and FFP-ITU without the TEC package do not have pins.

